

simpleaccess 

---

# 500 SERIES

RESIDENTIAL GRADE LEVER



1

Do this first:

**Hardware Installation**

# Need some help?



Visit us online.

[simpleaccess.devicewebmanager.com](http://simpleaccess.devicewebmanager.com)



We're here to help.

1 (833) 413 0212

[support@simpleaccess.com](mailto:support@simpleaccess.com)

## Here's what you'll need:

- ✓ Four AA Batteries
- ✓ Phillips Screwdriver

### **OPTIONAL:**

- ✓ Power Drill
  - 2 1/8" Hole Saw
  - 1" Drill Bit
- ✓ Measuring Tape
- ✓ Adhesive Tape

# What's in the box?

Let's make sure you have everything you need.  
If you're missing anything, contact  
[support@simpleaccess.com](mailto:support@simpleaccess.com).



Interior Lock



Exterior Lock



Mounting Plate



Strike Plate



Key Set



Latch



Hardware Pack

## You are here.

1

### **Install your lock.**

Use this Hardware Installation Guide to get your lock installed.

2

### **Get connected.**

Use the Connection Guide to get your lock online and registered.

3

### **Take control.**

Now your lock is fully functional and can be managed from anywhere.

## Find more help online.

For additional installation instructions and troubleshooting tips, be sure to visit our online support site:

[simpleaccess.devicewebmanager.com](https://simpleaccess.devicewebmanager.com)

Or contact us via phone or email:

**1 (833) 413 0212**

[support@simpleaccess.com](mailto:support@simpleaccess.com)

# Let's get started.

First things first, let's get your new lock installed.

## Drilling new holes?

Most doors will have an existing hole drilled for a lever lock. If your door needs to be drilled, you'll need to drill a 2 1/8" (54mm) hole for the lockset on the face of the door, as well as a 1" bore hole for the latch on the edge of the door.

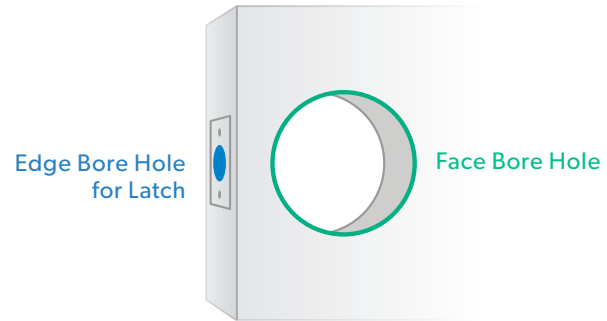

## STEP 1

# Position the template.

If your door already has a latch and face bore hole, please proceed to **STEP 3**.

Use the template to the right to mark the center of each hole precisely. Once the template is aligned, tape the template in place.

### Quick Tip

The **backset** is the distance between the center of the **face bore hole** to the edge of the door.

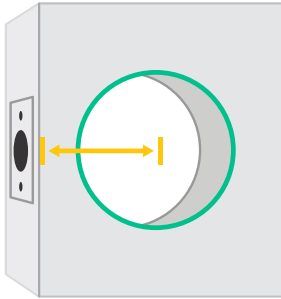

## TEMPLATE

Fold and fit door edge on this line.

Drill a 1 in diameter latch hole at the exact center of your door's edge.

Drill a  $2\frac{1}{8}$  in (54mm) diameter hole for either a  $2\frac{3}{4}$  in or  $2\frac{3}{8}$  in backset.

2" 13/4" 1 9/16" 40mm 13/8" 35mm

$2\frac{3}{4}$  in (70mm)

$2\frac{3}{8}$  in (60mm)

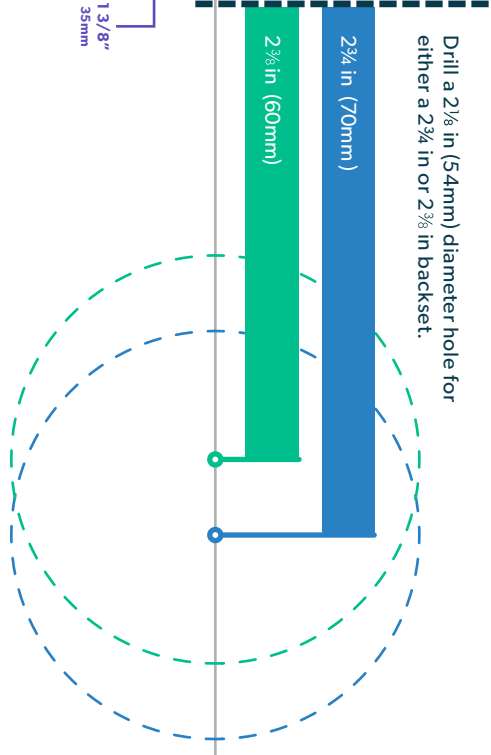

# TEMPLATE

Fold and fit door edge on this line.

Drill a 2 1/8 in (54mm) diameter hole for either a 2 3/4 in or 2 5/8 in backset.

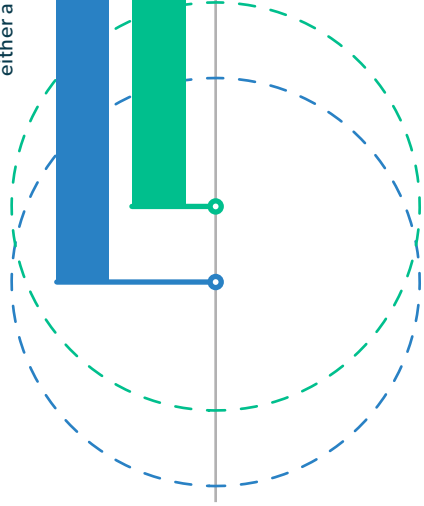

Drill a 1 in diameter latch hole at the exact center of your door's edge.

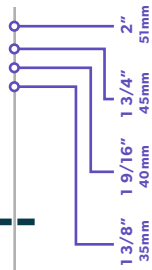

## Exterior of Door



## Interior of Door

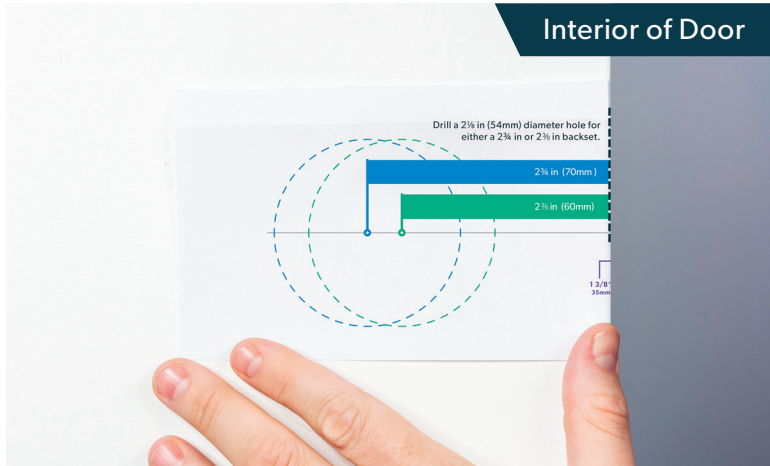

## STEP 2

# Mark carefully and drill.

Use a thumbtack or sharp object to mark the center of each hole you will drill. Mark the exterior of the door, then apply the template to the interior of the door.

Make sure the holes are aligned precisely from one side of the door to the other and double check all the measurements and markings.





Align the drill bit over your mark and hold the door steady. Keep the drill level and straight. Drill the 2 1/8" face bore halfway through on the first side.

Then drill the remaining half from the other side of the door. This prevents damage to the door and improves accuracy.

Finally, use a 1" drill bit to drill the edge of the door with the latch bore hole. Drill until you reach the face bore hole.

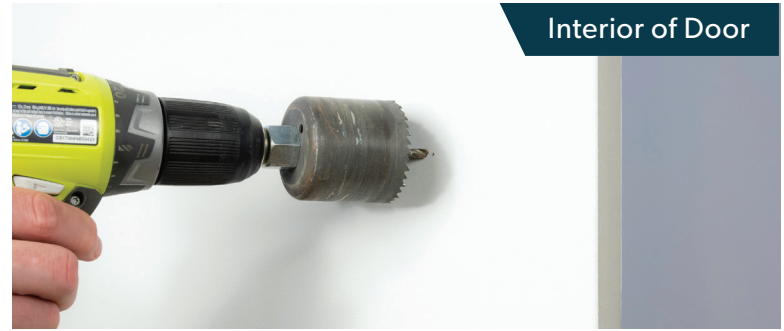

### STEP 3

## Measure the backset and adjust the latch to fit.

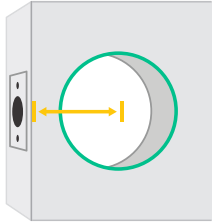

The **backset** is the distance between the center of the **face bore hole** to the edge of the door.

The lever latch has two positions, when retracted it will fit a 2 <sup>3</sup>/<sub>8</sub>" (60mm) backset or when extended, will fit a 2 <sup>3</sup>/<sub>4</sub>" (70mm) backset.

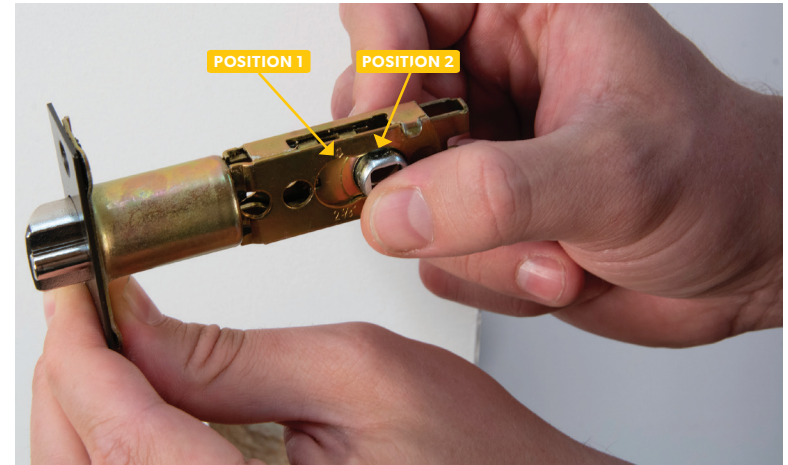
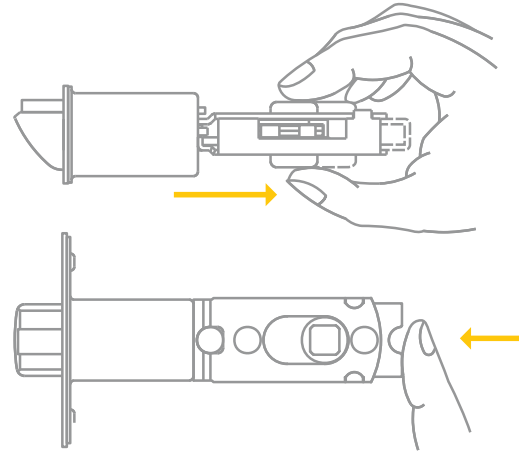

## STEP 4

# Install latch.

Insert the latch and make sure it is flush with the door frame. Ensure the  symbols on the latch are pointed up. Hand tighten with two of the included wood screws.



The guard latch should face the exterior of the door.

### Quick Tip

Make sure the latch plate lays flush with the door. If the latch plate is not flush with the door, draw an outline around the faceplate edge and chisel a rebate to allow the latch to lay flush with the door edge.

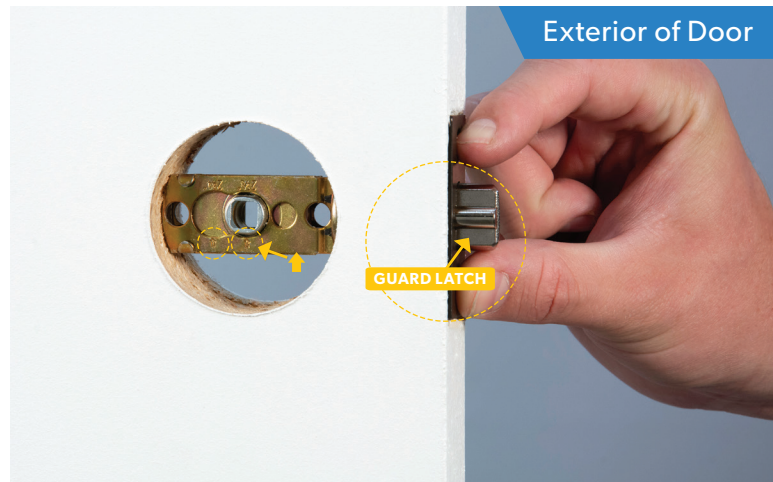

## STEP 5

# Position keypad.

Place the keypad portion of the lock on the exterior side of the door. Pass the power cable over the latch to the interior side of the door. Ensure the tailpiece is in the vertical position and inserted through the hub of the latch.

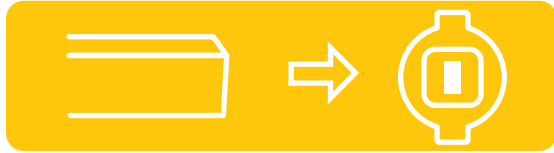

### Quick Tip

Make sure the power cable is inserted **above** the latch and the latch tailpiece is in the vertical position..



## STEP 6

# Attach mounting plate.

Hold the mounting plate up to the interior of the door, making sure the prongs are facing up and outward.

Pass the power cable through the upper center hole on the mounting plate. Secure the mounting plate to the exterior half of the lock with the two included long bolts. If the lock appears crooked or lopsided, loosen the screws, adjust its position, and retighten.

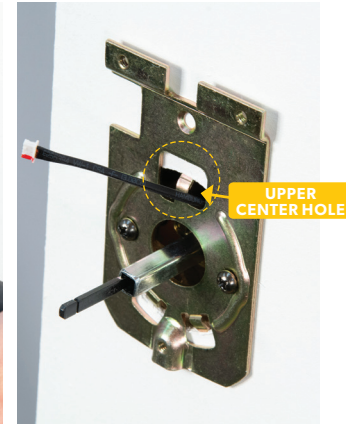
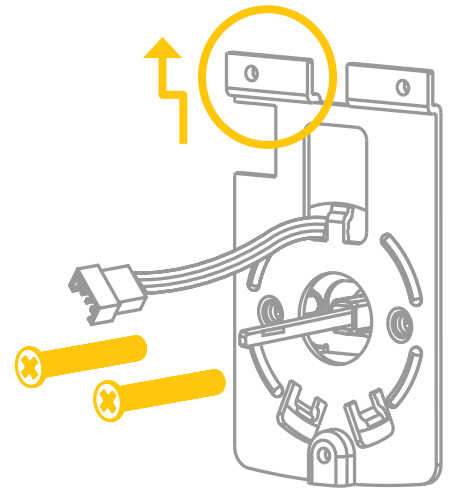

## STEP 7

# Prepare the interior lock.

Remove the battery cover from the interior of the lock by sliding the cover upward and pulling it off.

The lever lock's thumb turn should still be in the horizontal, unlocked position and the tailpiece slot should be in the vertical position.

### Quick Tip

Take a picture of the serial number sticker on the back of the lock. The serial number can also be found on the exterior of the lock's packaging.

Remote  
**LOCK**



Model : OE-500  
Serial : AC000W000000000  
MacID : E04F00000000



## STEP 8

# Attach interior lock.

Connect the front lock's power cable to the interior lock.

Next, place the interior lock on the mounting plate making sure it is pressed flush to the door and the screw holes align with the mounting plate. Secure the interior lock to the mounting plate using the 3 included short bolts.

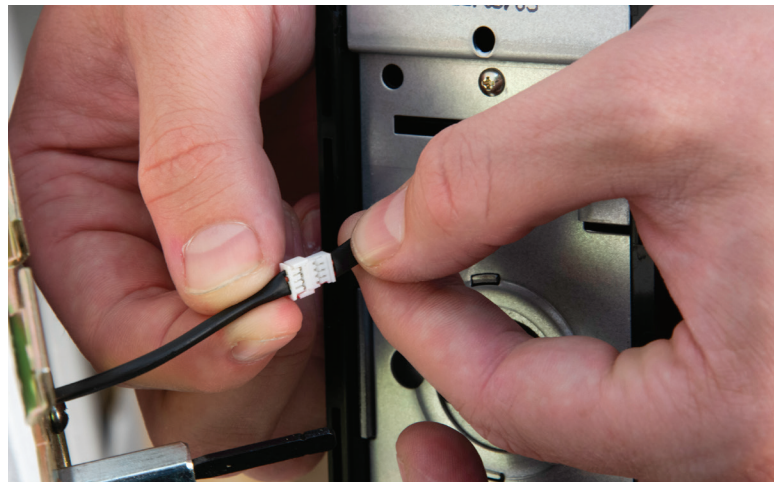

## (OPTIONAL STEP)

A wood screw is provided and can be used to screw the lock directly to a wood door in a more permanent and secure manner. This hole is located in the top, middle portion of the battery compartment.

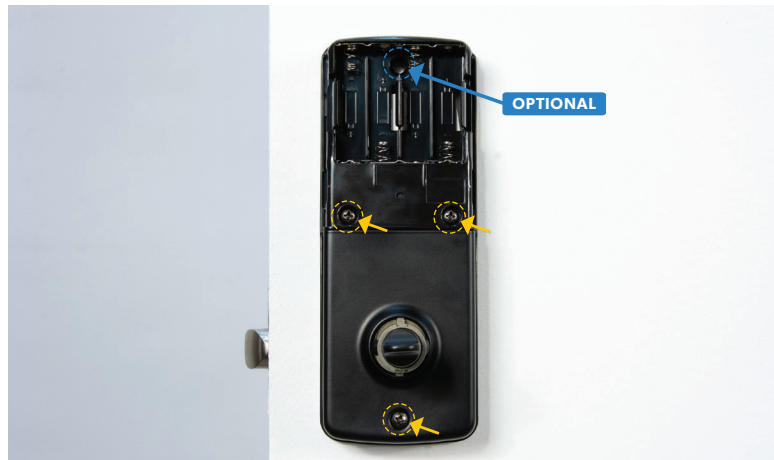

## STEP 9

# Install handles.

With the levers still in the unlocked position, insert the provided pin wrench into the small hole on the neck of the lever and apply pressure to depress the catch. Once the catch has been depressed, pull out the lever from the stem. Follow the same steps to remove the lever from the other side of the lock to exchange the position of the levers or change the lock's 'handing'.

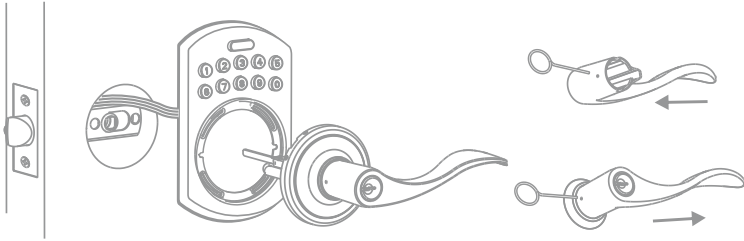

### Quick Tip

Lever handles should face away from the edge of the door to ensure smooth and ergonomic opening and closing.

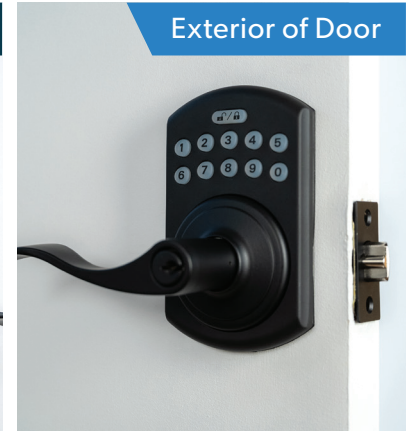



## STEP 10

# Insert batteries.

Insert four AA alkaline or lithium batteries into the battery compartment. Slide the battery cover back onto the lock.

Rechargeable batteries should never be used in this device because they do not support the necessary voltage. Please only use name brand alkaline or lithium batteries.

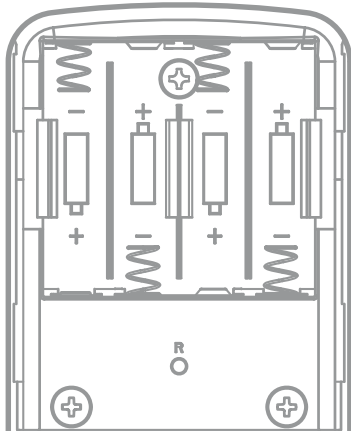

## STEP 11

# Test your lock.

First, press the  button to lock the lock.

Then enter the factory default code **1234**, followed by the  button to unlock the lock.

The keypad will flash green and the lever will now open freely. To lock the lock, press the  button.

Please note that, for security purposes, the default access code and Programming Code will be deleted after 24 hours or when your first access user is created. If you do not change the Programming Code yourself, it will be set to a randomized code for your protection. You can find this new code in the SimpleAccess app under device settings.

**Congratulations!**  
**Your lock is now  
installed.**

**Next:**  
**Use the Connection  
Guide to finish setup.**

# Using your lock.

## Locking

Lock the door by pressing the  button, by interior thumb turn, or with the included keys.

## Unlocking

Unlock the door by entering a user code followed by the  button on the keypad, by interior thumb turn, or with the included keys.

Once your lock is installed and connected to Wi-Fi, you can easily control your lock, add and manage access codes with the SimpleAccess app.

For a complete list of manual programming options, visit [simpleaccess.devicewebmanager.com](https://simpleaccess.devicewebmanager.com).

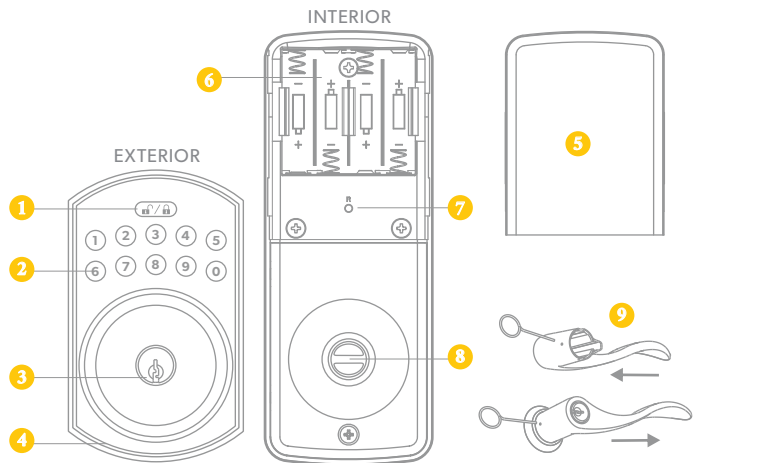

### 1 LOCK/UNLOCK BUTTON

The Lock/Unlock button is utilized for entering codes and setting functions. It's also a lock button.

### 2 NUMBER BUTTONS

Input buttons for codes and function programming.

### 3 CYLINDER

Lock/Unlock the lock from exterior.

### 4 GASKET

Prevent water permeating into lock.

### 5 BATTERY LID

Slide the lid to change the batteries.

### 6 BATTERY HOLDER

Four AA (1.5v) Alkaline or Lithium batteries only.

### 7 R BUTTON (RESET)

Restores default settings.

### 8 THUMB TURN

Lock/Unlock the lock from interior.

### 9 LEVER HANDLES

To open, close, and engage latch.

# Default Settings

By default, and after a factory reset, your lock has the following settings:

**Programming Code:** 123456

**User Code:** 1234

**Auto-Lock Mode:** Disabled



**Keypad Sound:** Enabled

**Heartbeat Interval:** 1 Hour

# Programming Functions

You can use the keypad to perform several functions. These functions can also be performed remotely from the SimpleAccess app. None of the following functions are required for setup.

All keypad programming functions follow the same general steps:

1. Enter your **Programming Code**, followed by the  button.
2. Enter the **Function Code** for the desired function, followed by the  button.
3. Some functions will also require you to enter a **Function Value**, followed by the  button.

# Specs and Functions

**Power:** 6V, four AA (1.5V) Alkaline or Lithium batteries only. Low Power or Low Battery life notifications are initially sent when the device reports battery at 30% or less. Once the battery has reached 30%, we will send additional low power notifications once per week until the device is dead.

**Programming Code:** The default programming code is **123456**. Please change this code for your security. Programming codes must be 4–10 digits.

**Local Codes:** Local codes are created using the programming code at the lock. There is a limit of 10 local codes. By default the code is **1234**. Local codes must be 4–10 digits.

**User Codes:** User codes are created using the app and can be configured with an access schedule. User codes must be 4–10 digits.

**Auto-Lock:** When disabled, the lock will remain unlocked after a code is entered. This mode is enabled by default on all OpenEdge Series Lever models. When Auto-Lock is enabled, the lock will automatically lock itself after the specified delay. A delay of 5 seconds is set by default.

**Restore Factory Defaults:** Factory settings can be restored by pressing and holding the “R” button on the battery pack within 10 seconds of power-cycling the lock (removing and reinserting a single battery).

## Illuminated Indications

**1 green flash:** successful operation or a button press.

**2 green flashes:** successful programming.

**3 red flashes:** operational or programming error.

**4 red flashes:** 4.25V low battery warning.

**8 red flashes:** 3.75V low battery warning.

**Orange flashes:** lock is in a programming sequence.

## Audio Indications

**1 beep** indicates successful operation or a button press.

**2 beeps** indicates successful programming.

**3 beeps** indicates a operational or programming error.

**4 beeps** indicates 4.25V low battery warning.



**8 beeps** indicates 3.75V low battery warning.

## Function Codes

### 100: Change Programming Code

The programming code is a password for your lock. This code will allow you to program the lock directly, using the keypad. By default, the code is **123456**.

You can change this code to any anything 4–8 digits in length. To set a new programming code, enter the following on the lock's keypad:







Enter your current  followed by the  button,  followed by , and then enter your  followed by .

If successful, you will see two green flashes and hear two beeps. If an error was made, you will see a red flash.

## 110: Add a Local Code

Local Codes are intended to be used as a backup to User Codes created from the app. If internet is unavailable, you can program a code directly from the lock. Note that schedules cannot be applied to a Local Code.

Local Codes can be 4–8 digits in length. To Add a Local Code, enter the following on the lock's keypad:







Enter your **Programming Code** followed by the /  button, **110** followed by / , and then enter your desired **Local User Code** followed by / .

Once set, the default User Code will be disabled after your Local Code is created.

## Function Codes (cont.)

### 120: Delete Local Code

If you would like to remove your Local Code, enter the following on the lock's keypad:

Enter your **Programming Code** followed by the /  button, **120** followed by / , and then enter the existing **Local User Code** followed by / .

### 130: Erase ALL Local Codes

If you would like to remove ALL of your existing Local Codes, enter the following on the lock's keypad:

Enter your **Programming Code** followed by the /  button, **130** followed by / .

## Additional Functions

For all these additional functions, enter the following on the lock's keypad:

Enter your  followed by the  button, then the corresponding  followed by .

**320:** Enter **320** followed by  to beacon the lock's network to connect Wi-Fi, or connect to a new network.

**131:** Erase all user codes, except **1234** default.

**135:** Perform a factory reset. Careful, this will **delete all codes, schedules and events**.

**160:** Mute keypad beeping.

**161:** Unmute keypad beeping.

**270:** Disable Passage Mode. Your lock will automatically lock after each use.

**271:** Enable Passage Mode. Your lock will stay unlocked after being unlocked.

**312:** Reset Wi-Fi connection. (Forget All Known Connections and Networks).

**320:** Enter Access Point Mode to allow connection to another network.

**411:** Enter **411** followed by  to force Wi-Fi to wake up if the lock is currently set to not wake up when keypad is pressed.

Changes or modifications not expressly approved by the party responsible for compliance could void the user's authority to operate this equipment.

This device complies with Part 15 of the FCC Rules. Operation is subject to following two conditions: (1) This device may not cause harmful interference, and (2) This device must accept any interference received, including interference that may cause undesired operation.





Visit us online.

[simpleaccess.devicewebmanager.com](http://simpleaccess.devicewebmanager.com)



We're here to help.

1 (833) 413 0212

[support@simpleaccess.com](mailto:support@simpleaccess.com)