

MR52 READER INTERFACE

Installation and Specifications:

This device complies with part 15 of the FCC Rules. Operation is subject to the following two conditions: (1) This device may not cause harmful interference, and (2) this device must accept any interference received, including interference that may cause undesired operation.

1. General:

The MR52 reader interface provides a solution to the OEM system integrator for interfacing to TTL (D1/D0, Clock/Data), F/2F, 2-wire RS-485 device, and door hardware. The MR52 provides a tri-state LED control and buzzer control. Six Form-C relay outputs may be used for strike control or alarm signaling. Eight inputs are provided that may be used for monitoring the door contact, request to exit push button and alarm contacts. Input circuits can be configured as unsupervised or supervised. Communication to the controller is accomplished via a 2-wire RS-485 interface.

The MR52 requires 12 to 24 Vdc for power. See the following figure for component location.

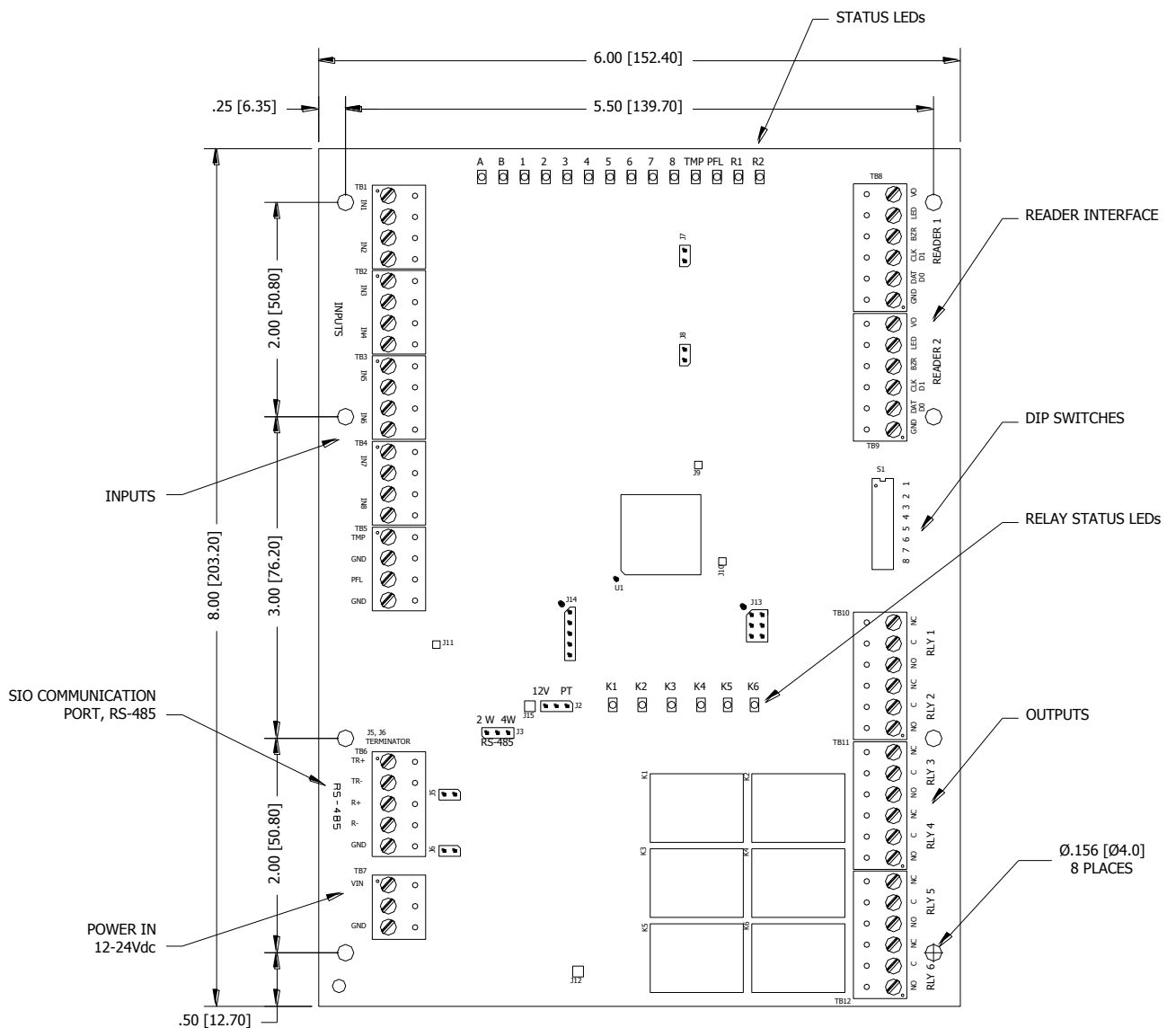

Information Subject to Change Without Notice

2. Supplying Power to the MR52:

The MR52 accepts 12 to 24 Vdc for power on TB7. Locate the power source as close to the MR52 as possible. Make power connection with minimum of 18 AWG wires.

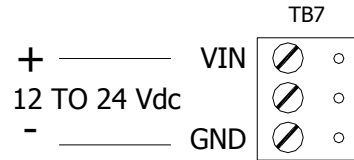

Observe POLARITY on VIN!

3. Communication Wiring (SIO Communication Port):

The MR52 communicates to a Mercury Security intelligent controller (EP2500 for example) via a 2-wire RS-485 interface. The MR52 allows for multi-drop communication on a bus of up to 4,000 feet (1,200 m). Use twisted pair (minimum 24 AWG) with drain wire and shield for communication. See specifications section.

Install jumpers according to the selected configuration.

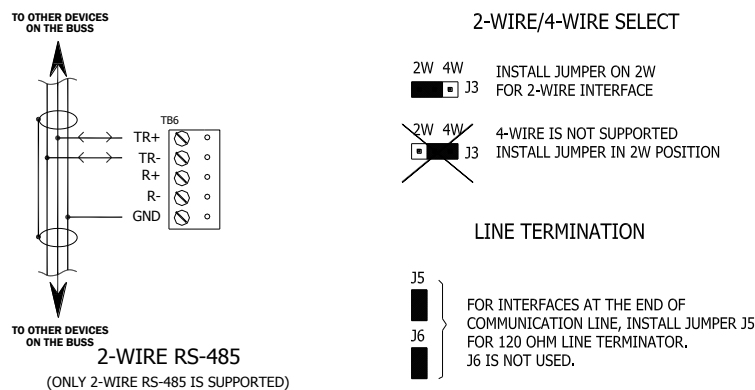

4. Reader Wiring:

Each reader port supports a reader with TTL (D1/D0, Clock/Data), F/2F, or 2-wire RS-485 signaling. Power to the reader is selectable: 12 Vdc (VIN must be greater than 20 Vdc), or power is passed-through (PT) from the input voltage of the MR52 (TB7-VIN), 180 mA maximum per reader port. Readers that require different voltage or have high current requirements must be powered separately. Refer to the reader manufacture specifications for cabling requirements. In the 2-wire LED mode the buzzer output is used to drive the second LED. Reader port configuration is set via the host software.

To fully utilize each reader port:

- TTL signaling requires a 6-conductor cable (18 AWG)
- F/2F signaling requires a 4-conductor cable
- RS-485 signaling requires two 2-conductor cables. Use one cable for power (18 AWG) and one cable for communication (24 AWG, with drain wire and shield)

12V PT	READER POWER
	12 Vdc IS AVAILABLE ON READER PORTS (VIN > 20 Vdc)
	VIN POWER IS "PASSED THROUGH" TO READER PORTS

J2 – Reader Port Power Select

If the input voltage to the MR52 is 12 Vdc, jumper J2 **MUST** be in the PT position.

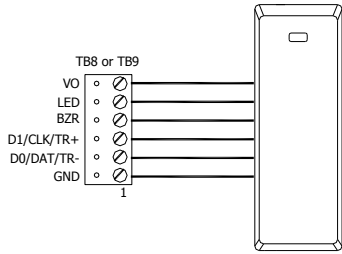

Typical D1/D0 – Clock/Data Reader

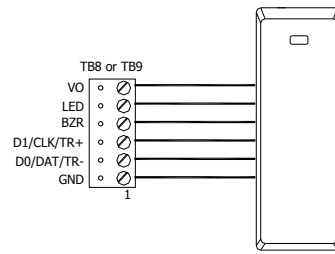

Typical 2-Wire RS-485 Device

* Inputs on supervised F/2F readers may be unsupervised or supervised (supervised shown).

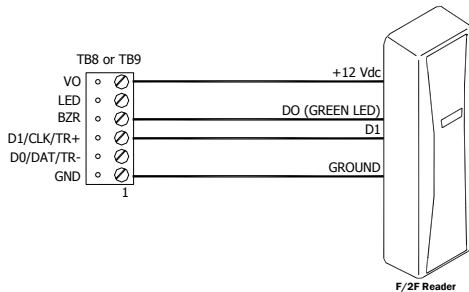

Typical Unsupervised F/2F Reader

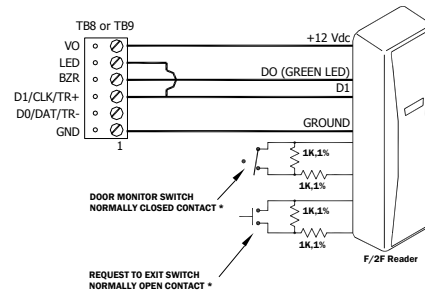

Typical Supervised F/2F Reader

 Jumper D1 to LED on supervised F/2F readers

5. Alarm Contract Wiring:

There are 8 inputs that are typically used to monitor door position, request to exit or alarm contacts. Input circuits can be configured as:

Unsupervised alarm (2 states); reporting as open or closed contact.

Supervised alarm (6 states); reporting as open or closed contact, open circuit, shorted circuit, grounded circuit *, or foreign voltage*.

A supervised input circuit requires adding two resistors with value of 1k ohm, 1% to the circuit to facilitate proper reporting and should be located as close to the sensor as possible. Custom end of line (EOL) resistances may be configured via the host software.

* Grounded and foreign voltage states are not a requirement of UL 294 and therefore not verified by UL.

The input circuit wiring configurations shown are supported but may not be typical.

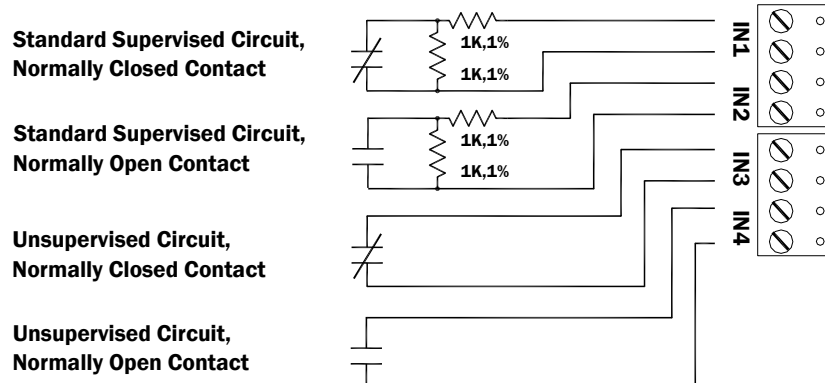

6. Control Output Wiring:

Six Form-C contact relays are provided for controlling door strikes or other devices. Load switching can cause abnormal contact wear and premature contact failure. Switching of inductive loads (strike) also causes EMI (electromagnetic interference) which may interfere with normal operation of other equipment. To minimize premature contact failure and to increase system reliability, contact protection circuit must be used. The following two circuits are recommended. Locate the protection circuit as close to the load as possible (within 12 inches [30 cm]), as the effectiveness of the circuit will decrease if it is located further away.

Use sufficiently large gauge of wires for the load current as to avoid voltage loss.

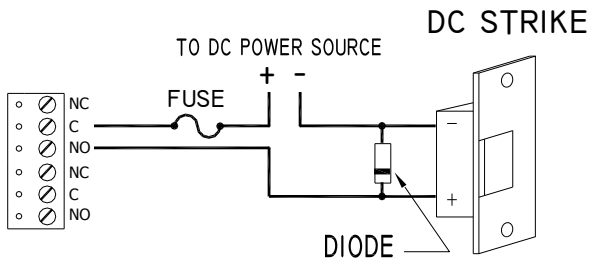

DIODE SELECTION:

Diode current rating > 1x strike current
 Diode break down voltage: 4x strike voltage
 For 12 Vdc or 24 Vdc strike, diode 1N4002
 (100V /1A) typical

7. Jumper and DIP Switch Usage:

JUMPER	DESCRIPTION
J2	Reader Power Select 12V = 12 Vdc at reader ports. *** See note below *** PT = VIN "Passed Through" to reader ports
J3	2-Wire/4-Wire Select, install in 2W position only
J5	RS-485 Termination, install in first and last units only
J6	Factory use only
J7	Factory use only
J8	Factory use only
J9	Factory use only
J10	Factory use only
J11	Factory use only
J12	Factory use only
J13	Factory use only
J14	Factory use only
J15	Factory use only

NOTE: The input power (VIN) must be 20 Vdc minimum if the 12 Vdc selection is to be used.

Switches 1 to 5 select the device address. Switch 6 and 7 select the communication baud rate. Switch 8 enables encrypted communication. All other configuration settings are set via host software.

S8	S7	S6	S5	S4	S3	S2	S1	SELECTION
			OFF	OFF	OFF	OFF	OFF	Address 0
			OFF	OFF	OFF	OFF	ON	Address 1
			OFF	OFF	OFF	ON	OFF	Address 2
			OFF	OFF	OFF	ON	ON	Address 3
			OFF	OFF	ON	OFF	OFF	Address 4
			OFF	OFF	ON	OFF	ON	Address 5
			OFF	OFF	ON	ON	OFF	Address 6
			OFF	OFF	ON	ON	ON	Address 7
			OFF	ON	OFF	OFF	OFF	Address 8

			OFF	ON	OFF	OFF	ON	Address 9
			OFF	ON	OFF	ON	OFF	Address 10
			OFF	ON	OFF	ON	ON	Address 11
			OFF	ON	ON	OFF	OFF	Address 12
			OFF	ON	ON	OFF	ON	Address 13
			OFF	ON	ON	ON	OFF	Address 14
			OFF	ON	ON	ON	ON	Address 15
			ON	OFF	OFF	OFF	OFF	Address 16
			ON	OFF	OFF	OFF	ON	Address 17
			ON	OFF	OFF	ON	OFF	Address 18
			ON	OFF	OFF	ON	ON	Address 19
			ON	OFF	ON	OFF	OFF	Address 20
			ON	OFF	ON	OFF	ON	Address 21
			ON	OFF	ON	ON	OFF	Address 22
			ON	OFF	ON	ON	ON	Address 23
			ON	ON	OFF	OFF	OFF	Address 24
			ON	ON	OFF	OFF	ON	Address 25
			ON	ON	OFF	ON	OFF	Address 26
			ON	ON	OFF	ON	ON	Address 27
			ON	ON	ON	OFF	OFF	Address 28
			ON	ON	ON	OFF	ON	Address 29
			ON	ON	ON	ON	OFF	Address 30
			ON	ON	ON	ON	ON	Address 31
	OFF	OFF						115,200 BPS, See note 1 below.
	OFF	ON						9,600 BPS
	ON	OFF						19,200 BPS
	ON	ON						38,400 BPS
OFF								Encrypted communication not required See note 2 below.
ON								Encrypted communication required See note 2 below.

Note 1: Firmware revisions prior to 1.38.1, this setting is 2,400 BPS

Note 2: Firmware revisions prior to 1.38.1, SW8 is not defined. Set to the OFF position

8. Status LEDs:

Power-up: All LED's OFF

Initialization: Once power is applied, initialization of the module begins

When initialization is completed, LEDs A through R2 are briefly sequenced ON then OFF

Run time: After the above sequence, the LEDs have the following meanings:

A LED: Heartbeat and On-Line Status:

Off-line: 1 sec rate, 20 % **ON**

On-line:

Non-encrypted communication: 1 sec rate, 80 % **ON**

Encrypted communication:

.1 sec **ON**, .1 sec **OFF**, .1 sec **ON**, .1 sec **OFF**, .1 sec **ON**, .1 sec **OFF**, .1 sec **ON**, .3 sec **OFF**

A LED Error Indication:

Waiting for application firmware to be downloaded: .1 sec **ON**, .1 sec **OFF**.

B LED: SIO Communication Port Status:

Indicates communication activity on the SIO communication port

1 LED: Input Status: IN1

2 LED: Input Status: IN2

3 LED: Input Status: IN3

4 LED: Input Status: IN4

5 LED: Input Status: IN5

6 LED: Input Status: IN6

7 LED: Input Status: IN7

8 LED: Input Status: IN8

TMP: Cabinet Tamper

PFL: Power Fault

Input in the inactive state: OFF (briefly flashes ON every 3 seconds)

Input in the active state: ON (briefly flashes OFF every 3 seconds)

Input in a trouble state: Rapid Flash

R1 LED: reader port 1:

Clock/Data Mode: Flashes when data is received, either input

D1/D0 Mode: Flashes when data is received, either input

RS-485 Mode: Flashes when transmitting data

F/2F Mode: Flashes when data/acknowledgment is received

R2 LED: reader port 2:

Clock/Data Mode: Flashes when data is received, either input

D1/D0 Mode: Flashes when data is received, either input

RS-485 Mode: Flashes when transmitting data

F/2F Mode: Flashes when data/acknowledgment is received

K1 through **K6** LEDs: Illuminates when output relay RLY 1 (K1) through RLY 6 (K6) is energized.

Every three seconds, LEDs **A** through **R2** are pulsed to their opposite state for 0.1 sec.

9. Specifications:

The Interface is for use in low voltage, class 2 circuits only.

The installation of this device must comply with all local fire and electrical codes.

Primary power: 12 to 24 Vdc \pm 10 %, 550 mA maximum (reader current not included)

Outputs: Six relays: Form-C, 5 A @ 30 Vdc, resistive

Inputs: Eight unsupervised/supervised, standard EOL: 1k/1k ohm, 1%, ¼ watt
Two unsupervised, dedicated for cabinet tamper and UPS fault monitoring

Reader Interface:

Power: 12 Vdc \pm 10 % regulated, 180 mA maximum each reader
(jumper selectable) (input voltage (VIN) must be greater than 20 Vdc)
or
12 to 24 Vdc \pm 10 % (input voltage passed through), 180 mA maximum each reader

Data Inputs: TTL compatible, F/2F or 2-wire RS-485

LED Output: TTL compatible, high > 3 V, low < 0.5 V, 5 mA source/sink maximum

Buzzer Output: Open collector, 12 Vdc open circuit maximum, 40 mA sink maximum

Communication:	2-wire RS-485: 9600, 19200, 38400 or 115200 bps
Cable requirements:	
Power:	1 twisted pair, 18 AWG
RS-485 I/O devices:	1 twisted pair with drain wire and shield, 24 AWG, 120 ohm impedance, 4,000 feet (1,200 m) maximum
Alarm inputs:	One twisted pair per input, 30 ohms maximum
Outputs:	As required for the load
Reader data (TTL):	6-conductor, 18 AWG, 500 feet (150 m) maximum
Reader data (F/2F):	4-conductor, 18 AWG, 500 feet (150 m) maximum
Reader data (RS-485):	1 twisted pair with drain wire and shield, 24 AWG, 120 ohm impedance, 2,000 feet (610 m) maximum
Mechanical:	
Dimension:	6 in. (152 mm) W x 8 in. (203 mm) L x 1 in. (25 mm) H
Weight:	11 oz. (312 g) nominal
Environment:	
Temperature:	-55 to +85 °C, storage 0 to +70 °C, operating
Humidity:	5 to 95 % RHNC

Warranty

Mercury Security warrants the product is free from defects in material and workmanship under normal use and service with proper maintenance for one year from the date of factory shipment. Mercury Security assumes no responsibility for products damaged by improper handling or installation. This warranty is limited to the repair or replacement of the defective unit.

There are no expressed warranties other than set forth herein. Mercury Security does not make, nor intends, nor does it authorize any agent or representative to make any other warranties, or implied warranties, and expressly excludes and disclaims all implied warranties of merchantability or fitness for a particular purpose.

Returns must be accompanied by a Return Material Authorization (RMA) number obtained from customer service, and prepaid postage and insurance.

Liability

The Interface should only be used to control exits from areas where an alternative method for exit is available. This product is not intended for, nor is rated for operation in life-critical control applications. Mercury Security is not liable under any circumstances for loss or damage caused by or partially caused by the misapplication or malfunction of the product. Mercury Security's liability does not extend beyond the purchase price of the product.